



FAA APPROVED

# Airplane Flight Manual

FOR

## **MAULE M-7-235C**

2800# UPGROSS PER STC SA04077CH-A  
APPLICABLE TO SERIAL NUMBERS 25115C & UP PER STC SA04077CH DATED:

Airplane Serial No. \_\_\_\_\_

Registration No. \_\_\_\_\_

THIS DOCUMENT MUST BE KEPT IN THE AIRPLANE AT ALL TIMES.

FAA APPROVED: Adrian P. Tower

for Timothy P. Smyth  
Manager, Aircraft Certification Office  
Federal Aviation Administration  
Chicago, IL USA

DATE: NOV 16 2016

**Performance That Counts!**

2099 Georgia Highway 133 South • Moultrie, GA 31788 •  
(229) 985-2045 • Fax: (229) 985-2048 or (229) 890-2402 • [www.mauleairinc.com](http://www.mauleairinc.com)

MAULE AEROSPACE TECHNOLOGY, INC.  
 AIRPLANE FLIGHT MANUAL  
**MAULE M-7-235C**  
 2800# Uppross Per STC SA04077CH

**LOG OF REVISIONS**

REV.	TO PAGES	DESCRIPTION	APPROVAL AND DATE
A	10, 12, 14, 15, 16, 19, 26	Corrected per FAA comments dated 10/27/16	FAA APPROVED:  <hr/> DATE: <b>NOV 16 2016</b> <hr/>

MAULE AEROSPACE TECHNOLOGY, INC.  
AIRPLANE FLIGHT MANUAL

**MAULE M-7-235C**

2800# Uppross Per STC SA04077CH

**LOG OF SUPPLEMENTS**

SUPP. NO.	NO. OF PAGES	DESCRIPTION	APPROVAL DATE
1	2	Tow Release Assembly installed in accordance with Maule drawing 3196F, Rev. G or later.	17 Jan 2013
4	8	Aqua Model 2400 Floats installed in accordance with Maule drawing 9135B, Rev. I or later.	02 Jun 2015

FAA APPROVED  
DATE: 11-16-16

MAULE AEROSPACE TECHNOLOGY, INC.  
 AIRPLANE FLIGHT MANUAL  
**MAULE M-7-235C**  
 2800# Uppgross Per STC SA04077CH

**Contents**

LOG OF REVISIONS .....	2
LOG OF SUPPLEMENTS .....	3
SECTION I - GENERAL: NORMAL CATEGORY OPERATION .....	6
1.1    MAXIMUM WEIGHT: 2800 Pounds.....	6
1.2    CENTER OF GRAVITY LIMITS: .....	6
1.3    MANEUVERS:.....	6
1.4    FUEL CAPACITY:.....	6
SECTION II - LIMITATIONS:.....	7
2.1    AIRSPEED LIMITS:.....	7
2.2    POWER PLANT LIMITS:.....	7
2.3    FLIGHT LOAD FACTORS:.....	9
2.4    PLACARDS: .....	9
SECTION III - NORMAL PROCEDURES: .....	10
3.1    PREFLIGHT INSPECTION: .....	10
3.2    OPERATING CHECK LISTS:.....	12
3.3    NORMAL FLIGHT OPERATIONS:.....	14
3.4    DOOR-OFF OPERATION: .....	16
3.5    NOISE LEVEL: .....	16
3.6    ANTI-COLLISION LIGHT: .....	16
SECTION IV - EMERGENCY PROCEDURES .....	16
4.1    EMERGENCY BASIC RULES:.....	16
4.2    ENGINE EMERGENCY SHUT DOWN: .....	16
4.3    ENGINE FIRE DURING STARTING: .....	17
4.4    ENGINE FIRE AFTER STARTING:.....	17
4.5    EMERGENCY EXIT ON THE GROUND:.....	17
4.6    TAKEOFF ABORT: (BEFORE LIFT-OFF) .....	17
4.7    ENGINE FAILURE AFTER TAKEOFF OR FORCED LANDING: .....	17
4.8    PARTIAL POWER FAILURE DURING FLIGHT OR AFTER TAKEOFF:.....	17
4.9    COMPLETE POWER FAILURE DURING FLIGHT:.....	17
4.10   ENGINE AIRSTART: .....	18
4.11   ELECTRICAL FIRE: .....	18
4.12   ENGINE FIRE DURING FLIGHT:.....	18
4.13   SMOKE AND FUME ELIMINATION:.....	18
4.14   STRUCTURAL DAMAGE: .....	18
4.15   RECOVERY FROM INADVERTENT SPINS: .....	18
4.16   ALTERNATOR FAILURE: .....	19
SECTION V .....	19
5.1    WEIGHT AND BALANCE .....	19
5.2    EQUIPMENT CHANGE - WEIGHT AND BALANCE.....	25
SECTION VI - AIRCRAFT SERVICING, HANDLING AND MAINTENANCE .....	26
6.1    INTRODUCTION: .....	26
6.2    AIRPLANE INSPECTION PERIOD:.....	26
6.3    PREVENTIVE MAINTENANCE THAT MAY BE ACCOMPLISHED BY A CERTIFIED PILOT:..	26
6.4    ALTERATIONS OR REPAIRS TO AIRPLANE: .....	26
SECTION VII - MANUFACTURER'S DATA.....	27
7.1    OPTIONAL AND REQUIRED EQUIPMENT LIST - PROVIDED FOR EACH AIRPLANE.....	27

MAULE AEROSPACE TECHNOLOGY, INC.  
AIRPLANE FLIGHT MANUAL

**MAULE M-7-235C**

2800# Ugross Per STC SA04077CH

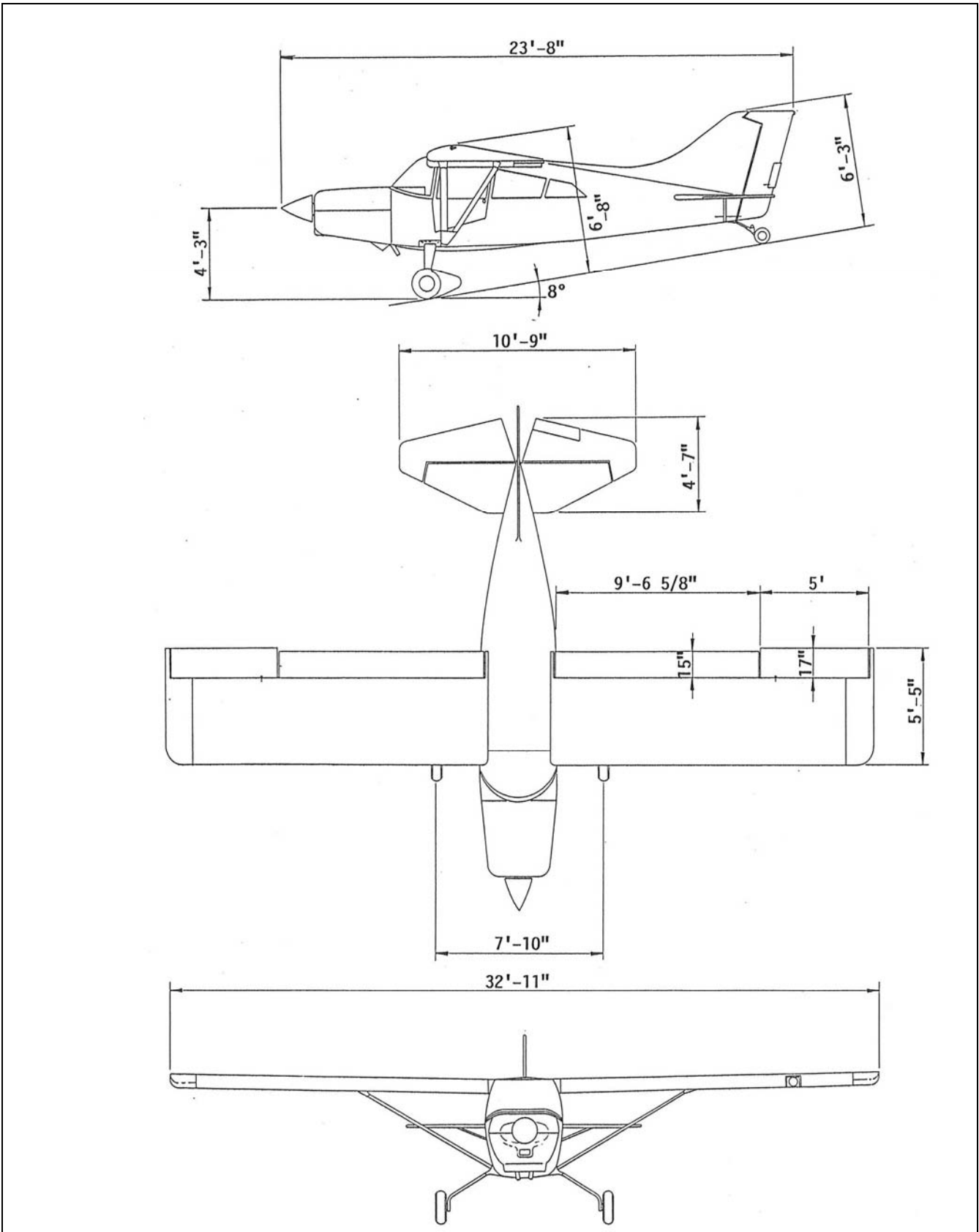

FAA APPROVED  
DATE: 11-16-16

**SECTION I - GENERAL: NORMAL CATEGORY OPERATION**

1.1 *MAXIMUM WEIGHT: 2800 Pounds*

1.2 *CENTER OF GRAVITY LIMITS:*

+16.2 to +20.5 @ 2800 lbs.

+12.5 to +20.5 @ 1700 lbs. or less

Straight line variation between points given

Datum: Wing Leading Edge

NOTE: It is the responsibility of the pilot to assure that the airplane is property loaded. Refer to the Weight and Balance Data for baggage/cargo loading recommendations and loading graphs.

//////////////////// CHECK WEIGHT AND BALANCE CAREFULLY, ESPECIALLY WHEN USING  
////CAUTION//// THE 5<sup>TH</sup> SEAT, IF INSTALLED, OR WHEN CARGO OR BAGGAGE IS CAR-  
//////////////////// RIED IN THE REAR CABIN AREA. ALSO, FLIGHT PLANNING SHOULD IN-  
CLUDE ALLOWANCE FOR FORWARD C.G. SHIFT WITH FUEL BURN.

1.3 *MANEUVERS:*

Only Normal Category Maneuvers including Stalls, Lazy Eights, Chandelles and steep turns involving bank angles not greater than 60° are approved in this airplane.

////////////////////  
////CAUTION//// AEROBATICS AND INTENTIONAL SPINS PROHIBITED.  
////////////////////

1.4 *FUEL CAPACITY:*

Usable Fuel: MAIN TANKS - 21.5 Gallons Each  
OPTIONAL AUXILIARY TANKS - 21.0 Gallons Each

Unusable Fuel: 2.3 Gallons Per Main Tank

////////////////////  
////CAUTION//// FUEL REMAINING IN TANK WHEN INDICATOR READS EMPTY CAN-  
//////////////////// NOT BE USED SAFELY IN FLIGHT.

**SECTION II - LIMITATIONS:**

**2.1 AIRSPEED LIMITS:**

All airspeeds are Indicated Airspeeds (IAS).

**A. AIRSPEED INDICATOR MARKINGS:**

Red Radial, (V<sub>NE</sub>) - 156K (180 mph)

Yellow Arc, Caution Range - 126 – 156K (145 – 180 mph)

Green Arc, Normal Operating Range – 53 - 126K (61 - 145 mph)

White Arc, Flap Operating Range – 43 - 82K (50 - 94 mph)

**B. EXPLANATION OF AIRSPEED INDICATOR MARKINGS:**

Red Radial Line - Never Exceed Speed (V<sub>NE</sub>) 156K (180 mph): Maximum safe airspeed in smooth air.

Yellow Arc - Caution Range, 126 – 156K (145 – 180 mph): Operation in this speed range should be conducted only in smooth air and control movements should not be large or abrupt.

Green Arc - Normal Operating Range, 53 - 126K (61 - 145 mph): Extends from flaps up, power off stall speed at 2800 lbs. (V<sub>s1</sub>) to design cruise speed (V<sub>c</sub>).

White Arc - Flap Operating Range, 43 - 82K (50 - 94 mph): Extends from full flap, power off minimum stall speed at 2800 lbs. (V<sub>so</sub>) to the Maximum flaps extended speed (V<sub>FE</sub>).

**2.2 POWER PLANT LIMITS:**

Engine: Lycoming O-540-B4B5

Engine Limits: 235 hp @ 2575 rpm, Full Throttle Continuous

Propeller: Hartzell: HC-C2YR-1BF/F8468A-6R (78") or -3R (81")  
Constant Speed (Use -3R with 7:00 tires or larger/26 psi minimum air pressure)

McCaughey: B3D32C414-C/G-82NDA-4 (78") or -2 (80")  
(use with J or W engines only) or  
B2D37C224-B/G-90RA-9 (81")  
(Use -2 with 7:00 tires or larger; use -9 with 7:00 tires or larger/26 psi minimum air pressure)

MAULE AEROSPACE TECHNOLOGY, INC.  
AIRPLANE FLIGHT MANUAL  
**MAULE M-7-235C**  
2800# Upgross Per STC SA04077CH

Fuel: 100/100LL Minimum Grade Aviation Gasoline

Engine Instrument Markings:

Cylinder Head Temperature:	Green Arc -	Normal Operating Range, 200°F - 435°F
	Red Radial -	Operating Limit, 500°F
Oil Temperature:	Green Arc -	Normal Operating Range, 140°F - 245°F
	Red Radial -	Operating Limit, 245°F
Oil Pressure:	Green Arc -	Normal Operating Range, 55 to 95 PSI
	Yellow Arc -	Caution Range, 25 to 55 PSI and 95 to 115 PSI
	Red Radial -	Minimum Operating Pressure, 25 PSI
	Red Radial -	Maximum Operating Pressure, 115 PSI
Manifold Pressure	Green Arc -	Normal Operating Range, 14.5 to 29 ins. of Mercury
Fuel Pressure	Green Arc -	Normal Operating Range, 0.5 to 8 PSI
	Red Radial -	Minimum Pressure, 0.5 PSI, Maximum Pressure, 8.0 PSI
Tachometer:	Green Arc -	Normal Operating Range, 2200 - 2575 RPM
	Red Radial -	Maximum RPM, 2575 RPM

//////////////////// DO NOT EXCEED 23 INCHES M.P. BELOW 2050 RPM. WHEN EQUIPPED  
////CAUTION//// WITH THE HARTZELL -6R (78") PROP. THIS IS A VIBRATORY STRESS  
//////////////////// LIMITATION WHICH APPLIES ONLY TO THIS MODEL PROPELLER.



### 2.3 FLIGHT LOAD FACTORS:

Flaps Fully Retracted: 3.8g Positive to 1.5g Negative  
Flaps Extended: 1.9g Positive to 0g Negative

NOTE: DESIGN MANEUVERING SPEED: The maximum safe airspeed at which full aerodynamic controls can be applied ( $V_A$ ) is 109K (125 mph). This airspeed is not marked on the airspeed indicator.

### 2.4 PLACARDS:

The following placards are in the cockpit in clear view of the pilot:

THIS AIRPLANE MUST BE OPERATED AS A NORMAL CATEGORY AIRPLANE IN COMPLIANCE WITH THE OPERATING LIMITATIONS STATED IN THE FLIGHT MANUAL AND IN THE FORM OF PLACARDS AND MARKINGS.

NO AEROBATIC MANEUVERS INCLUDING SPINS, APPROVED.

MANEUVERING SPEED 109K (125 MPH) IAS.

SEE LOADING INSTRUCTIONS IN WEIGHT AND BALANCE SECTION OF AIRPLANE FLIGHT MANUAL.

THIS AIRPLANE APPROVED FOR DAY OR NIGHT IFR NON-ICING FLIGHT WHEN EQUIPPED IN ACCORDANCE WITH FAR 91 OR FAR 135.

DO NOT TURN OFF ALTERNATOR IN FLIGHT EXCEPT IN CASE OF EMERGENCY.

FUEL REMAINING IN TANK WHEN INDICATOR READS ZERO CANNOT BE USED SAFELY IN FLIGHT.

DEMONSTRATED CROSSWIND 12K (14 mph)

When equipped with Hartzell -6R (78") 2 blade propeller:

DO NOT EXCEED 23 INCHES M.P. BELOW 2050 RPM.

At the main fuel tank selector valve on the left kick panel:

FUEL SELECTOR VALVE	
LEFT: 21.5 GAL.	
OFF	BOTH
RIGHT: 21.5 GAL.	

MAULE AEROSPACE TECHNOLOGY, INC.  
 AIRPLANE FLIGHT MANUAL  
**MAULE M-7-235C**  
 2800# Uppgross Per STC SA04077CH

On the instrument panel at the auxiliary tank transfer switches:

FUEL TRANSFER PUMPS

PUSH FOR AUX. QUANT.	PUSH FOR AUX. QUANT.
LEFT	RIGHT

**If JPI EDM-930 units are installed, the PUSH FOR AUX. QUANT. buttons and placards are not installed. However, FUEL TRANSFER PUMPS and LEFT and RIGHT placards are used**

FUEL CAPACITY: MAIN TANKS 21.5 GAL. USABLE EACH,  
 AUX. TANKS 21.0 GAL. USABLE EACH.

On flap control handle:

FLAPS / PULL ON / 2<sup>ND</sup> NOTCH / TAKEOFF / 4<sup>TH</sup> NOTCH / LANDING.

In rear cabin area:

CARGO OR BAGGAGE LIMITATIONS  
 MAX. LOAD AREA "A" 100 LBS.  
 MAX. LOAD AREA "B" 200 LBS.  
 MAX. LOAD AREA "C" 125 LBS.

Or also in rear cabin area when 5<sup>th</sup> seat is not installed:

CHECK WEIGHT AND BALANCE CAREFULLY WHEN  
 USING 5<sup>TH</sup> SEAT OR LOADING REAR CARGO/BAGGAGE.  
 MAXIMUM REAR SEAT LOADING IS 170 LBS.

On the lower window frame near the latch when optional swing out windows are installed:

WINDOW MUST BE CLOSED ABOVE 120 MPH

**SECTION III - NORMAL PROCEDURES:**

**3.1 PREFLIGHT INSPECTION:**

**A. INTERIOR:**

- |    |                              |   |
|----|------------------------------|---|
| 1. | BAT Switch.....              | ON  |
| 2. | Fuel Gauges.....             | CHECK INDICATIONS                         |
| 3. | Auxiliary Fuel Pumps.....    | ON, THEN OFF (LISTEN TO VERIFY OPERATION) |
| 4. | All Electrical Switches..... | OFF                                       |
| 5. | BAT Switch.....              | OFF                                       |
| 6. | Flaps.....                   | FULL DOWN (4TH NOTCH)                     |

MAULE AEROSPACE TECHNOLOGY, INC.  
AIRPLANE FLIGHT MANUAL

**MAULE M-7-235C**

2800# Uppross Per STC SA04077CH

EXTERIOR: Begin at the left front door, proceed around the left wing to the nose area, then around the right wing and back to the fuselage, then around the tail section.

- |  |   |
|--|---|
| 1. Fuel drains behind step.....              | DRAIN (2)   |
| 2. Left Flap.....                            | CHECK HINGES & CONTROL AT-TACHMENTS                                   |
| 3. Aileron.....                              | CHECK HINGES & CONTROL AT-TACHMENTS                                   |
| 4. Left Wing Top.....                        | CHECK FOR WRINKLES AS INDICA-TION OF INTERNAL DAMAGE                  |
| 5. Left Wing Main & Aux Fuel Tank Drain..... | DRAIN (2)   |
| 6. Left Wing Tip & Nav Light.....            | CHECK FOR DAMAGE  |
| 7. Auxiliary Fuel Tank.....                  | VISUALLY CHECK QUANTITY   |
| 8. Landing Light.....                        | CHECK FOR DAMAGE  |
| 9. Left Wing Tiedown.....                    | REMOVE  |
| 10. Pitot Tube.....                          | REMOVE COVER  |
| 11. Stall Warning Switch.....                | CHECK FOR FREEDOM OF MOVE-MENT  |
| 12. Main Fuel Tank.....                      | VISUALLY CHECK QUANTITY   |
| 13. Left Landing Gear.....                   | CHECK TIRE INFLATION AND BRAKE LINE SECURITY                          |
| 14. Bottom left side of Cowl.....            | DRAIN GASCOLATOR (1)  |
| 15. Top Cowl, Oil Access Door.....           | CHECK OIL QUANTITY  |
| 16. Propeller.....                           | CHECK LEADING EDGE FOR DAM-AGE.                                       |
| 17. Air Inlets.....                          | CHECK FOR FOREIGN OBJECTS, INSPECT VISIBLE CONNECTIONS AND COMPONENTS |
| 18. Right Landing Gear.....                  | CHECK TIRE INFLATION & BRAKE LINE SECURITY                            |
| 19. Right Wing & Controls.....               | INSPECT SAME AS LEFT WING   |
| 20. Wing Main & Aux Fuel Tank Drain.....     | DRAIN (2)   |
| 21. Right Fuselage, Side, Top & Bottom.....  | INSPECT FOR WRINKLES AS INDI-CATION OF INTERNAL DAMAGE                |
| 22. Right Side Static Port.....              | CLEAR   |
| 23. Right Stabilizer.....                    | CHECK ATTACHMENT POINTS & STRUT                                       |
| 24. Right Elevator.....                      | CHECK HINGE POINTS  |
| 25. Rudder.....                              | CHECK HINGE POINTS, CONTROL ATTACHMENT & NAV LIGHT                    |
| 26. Tailwheel.....                           | CHECK FOR INFLATION, ATTACH-MENTS, REMOVE TIEDOWN                     |
| 27. Left Elevator.....                       | CHECK TAB CONTROLS & ALL HINGE POINTS                                 |
| 28. Left Stabilizer.....                     | CHECK ATTACHMENT POINTS & STRUT                                       |
| 29. Left Fuselage, Side, Top & Bottom.....   | CHECK FOR WRINKLES AS INDICA-TION OF INTERNAL DAMAGE                  |
| 30. Left Side Static Port.....               | CLEAR   |

3.2 OPERATING CHECK LISTS:

A. BEFORE STARTING:

- 1. Seat Belts & Shoulder Harnesses..... FASTENED
- 2. Flaps..... RETRACTED
- 3. Circuit Breakers..... CHECK

B. STARTING:

- 1. Parking or Toe Brakes..... ON
- 2. Fuel Selector Valve..... ON FULLEST TANK, OR BOTH IF SAME QUANTITY
- 3. Throttle..... OPEN 1/4 INCH
- 4. Propeller Control..... FULL INCREASE RPM
- 5. Mixture Control..... RICH (SEE NOTE FOR HOT START)
- 6. Anti-Collision Light..... ON
- 7. BAT and ALT Switch..... ON
- 8. Primer . .... AS REQUIRED
- 9. Starter Switch..... TWIST FULL RIGHT TO ENGAGE

////////// FOR A HOT START, DO NOT PRIME. A HOT ENGINE MAY FLOOD ON A  
////NOTE//// START ATTEMPT. TO CLEAR A FLOODED ENGINE, PULL MIXTURE FULL  
////////// LEAN AND OPEN THROTTLE, CRANK WITH STARTER. WHEN ENGINE  
STARTS, PULL THROTTLE TO IDLE AND EASE MIXTURE TO FULL RICH.

////////// IN EVENT OF ENGINE FIRE, CONTINUE CRANKING. PULL MIXTURE TO  
////CAUTION//// FULL LEAN. IF ENGINE FAILS TO START AFTER SEVERAL REVOLU-  
////////// TIONS, AND FIRE CONTINUES, SECURE IGNITION, BAT. AND ALT.  
SWITCHES, TURN FUEL VALVE OFF AND EXIT AIRCRAFT.

- 12. After Starting..... CHECK OIL PRESSURE

////////// IF OIL PRESSURE DOES NOT EXCEED 25 PSI WITHIN 30 SECONDS,  
////CAUTION//// SHUT DOWN ENGINE.  
//////////

- 13. Alternator..... CHECK CHARGING
- 14. Radios & other electrical switches..... AS REQUIRED
- 15. Parking Brake..... OFF

C. ENGINE CHECK:

- 1. Parking Brake..... ON, IF DESIRED
- 2. Engine Instruments..... CHECK, IN GREEN ARCS
- 3. Throttle..... INCREASE TO 2000 RPM
- 4. Magnetos..... SWITCH TO RIGHT, LEFT, BOTH,  
CHECKING RPM DROPS

////////////////////  
////CAUTION////  
////////////////////

A RPM DROP OF MORE THAN 175 RPM OR A DIFFERENCE BETWEEN LEFT AND RIGHT OF MORE THAN 50 RPM IS UNACCEPTABLE.

- 5. Propeller Control..... RETARD SLOWLY UNTIL MAXIMUM OF 500 RPM DROP IS NOTED. RETURN TO FULL INCREASE RPM. REPEAT. SET FULL INCREASE RPM
- 6. Carburetor Heat Control ..... PULL HOT, NORMAL DROP WITH CARBU RETOR AIR HOT IS 150 ±50 RPM
- 7. Carburetor Air Control..... PUSH COLD
- 8. Vacuum Gauge..... CHECK IN GREEN
- 9. Alternator..... CHARGING: LIGHT OUT ABOVE 900 RPM
- 10. Throttle..... RETARD TO IDLE

D. BEFORE TAKEOFF:

- 1. Fuel Selector..... ON FULLEST TANK OR BOTH
- 2. Flaps..... AS DESIRED FOR T.O. (MAX. 24°)
- 3. Trim Controls..... SET FOR TAKEOFF
- 4. Flight Controls..... CHECK FOR FREEDOM AND PROPER TRAVEL
- 5. Mixture Control..... FULL RICH
- 6. Propeller Control..... FULL INCREASE RPM
- 7. Carburetor Air Control..... PUSH COLD
- 8. Engine Instruments..... RECHECK IN NORMAL RANGE
- 9. Radios..... AS DESIRED
- 10. Altimeter..... SET
- 11. Attitude Indicator..... CHECK ERECT
- 12. Directional Indicator..... SET
- 13. Seat Belts & Shoulder Harnesses..... RECHECK FASTENED
- 14. Doors..... CLOSED & LATCHED
- 15. Passengers..... BELTS & HARNESSSES SECURED. BRIEFED ON OPENING DOORS.
- 16. Parking Brake..... OFF (PUSH KNOB COMPLETELY AGAINST INSTRUMENT PANEL)

E. BEFORE LANDING:

- 1. Seat Belts & Shoulder Harnesses..... FASTENED
- 2. Fuel Selector Valve..... ON FULLEST TANK OR BOTH
- 3. Mixture Control..... FULL RICH
- 4. Propeller Control..... FULL INCREASE RPM
- 5. Flaps..... AS REQUIRED
- 6. Carburetor Air Control..... PULL HOT (AS REQUIRED) (PUSH KNOB COMPLETELY AGAINST INSTRUMENT PANEL)

F. ENGINE SHUT DOWN:

- |                                       |                        |
|---------------------------------------|------------------------|
| 1. Parking Brakes.....                | ON, IF DESIRED         |
| 2. Radios.....                        | OFF                    |
| 3. All other electrical switches..... | AS DESIRED             |
| 4. Flaps.....                         | AS DESIRED             |
| 5. Magneto Grounding Check.....       | PERFORM BELOW 1000 RPM |
| 6. Mixture Control.....               | FULL LEAN              |
| 7. Magneto Switch.....                | OFF                    |
| 8. Anti-Collision Light.....          | OFF                    |
| 9. BAT & ALT Switch.....              | OFF                    |
| 10. Parking Brake.....                | OFF (AS DESIRED)       |

3.3 NORMAL FLIGHT OPERATIONS:

A. NOTE: FLAP SETTINGS:

The following Flap Settings are available:

Flap Configuration	Flap Handle Position	Flap Position
Cruise	Handle Full Down	-7°
Flaps Up	First Notch	0°
Takeoff	Second Notch	24°
Landing	Third Notch (optional)	40°
Landing	Fourth Notch	48°

B. RECOMMENDED FLAP SETTINGS:

Flap settings are given in number of notches above the fully retracted position, which is handle full down (Normal -7°).

NOTE: The airplane meets CAR 3 takeoff climb requirements at 78K (90 mph) IAS with the flaps selected in any of the following three positions: (a) Fully Retracted, Handle Full Down (-7°), (b) First Notch (0°), and (c) Second Notch (24°).

C. CLIMBING:

Best Rate of Climb – 78K (90 mph) IAS, flaps @ First Notch (0°)

Best Angle of Climb – 65K (75 mph) IAS with flaps set @ Second Notch (24°)

Cruise - Fully retracted (-7°/no notches or 0°/ 1<sup>st</sup> notch)

Landing - Normally Fourth Notch (48°/full flaps)\* - other positions optional

D. RECOMMENDED AIRSPEEDS:

Lift Off - 60K (69 MPH)

Approach - 70 - 75K (81 - 86 MPH)

//////////////////// FOR TAKEOFF OR LANDING UNDER GUSTY CROSSWIND CONDI-  
////CAUTION//// TIONS, FLAP SETTING OF 0° (one notch) IS RECOMMENDED. -7°  
//////////////////// OPTIONAL.

//////////////////// USE CLIMB AIRSPEED BELOW 78K (90 MPH) ONLY AS NECESSARY  
////CAUTION//// AND CHECK CYLINDER HEAD TEMPERATURE FREQUENTLY WHEN  
//////////////////// DOING SO.

E. RUDDER TRIM:

NOTE: To assure full effectiveness of the Right Rudder Trim:

Unlock "T" handle (½ turn left), depress right rudder as you pull "T" handle full out. Lock "T" handle ½ turn right before releasing right rudder pressure. If too much trim, move handle in until trim is correct and then lock.

F. STALLS:

Stalls are preceded by mild buffet that can be felt through the rudder pedals. The red stall warning light on the instrument panel will illuminate at 4 to 9K (5 to 10 mph) above the stall speed. Loss of altitude prior to recovery from a stall may be as much as 300 feet.

//////////////////// THE STALL WARNING LIGHT IS INOPERATIVE WHEN THE BATTERY  
////CAUTION//// SWITCH IS OFF  
////////////////////

G. CROSSWIND LANDINGS & TAKEOFFS:

Maximum demonstrated crosswind component is 12K (14 mph) and flap extension should be limited to 0° (first notch) with such crosswind or higher. 12K (14 mph) is the maximum demonstrated for certification of the airplane and is not considered limiting with flaps at 0°

H. FUEL SYSTEM MANAGEMENT:

Fuel is fed to the engine from the main (inboard) tanks and is controlled by the selector valve on the left kick panel. Auxiliary (outboard) tanks feed their respective main tanks via transfer pumps that are controlled by switches on the instrument panel. These transfer pumps transfer fuel at a rate of 0.4 gallons per minute or approximately 45 minutes for a full auxiliary tank. Since overfilling a main tank from an auxiliary tank will force excess fuel overboard, it is recommended that the transfer pumps not be activated until their respective main tanks are slightly more than one quarter full. If the tank being transferred to is feeding the engine, however, transfer can be initiated when the main tank is down to approximately one half. Do not exceed more than ¾ fuel capacity of main tank. Confirm fuel transfer by illumination of the transfer pump switch, an increase in the respective main tank fuel gauge indicator, and a decrease on the respective auxiliary tank indicator.

**MAULE M-7-235C**

2800# Uppgross Per STC SA04077CH

**3.4 DOOR-OFF OPERATION:**

This aircraft may be operated with either one (not both) of the front doors removed, or when both front doors are installed, with the rear passenger door or rear passenger and baggage doors off. When doing so, observe the following additional limitations:

1. Maximum airspeed – 109K (125 mph)
2. Maximum bank angle - 30°
3. Maximum yaw angle - 10°
4. No Smoking permitted
5. Limit flight to VFR conditions

**3.5 NOISE LEVEL:**

The noise levels obtained during certification per FAR 36, were:

with Hartzell	-6R (78")	2 blade	73.9 dBA
with Hartzell	-3R (81")	2 blade	73.9 dBA

The noise levels obtained during certification per FAR 36, Appendix G were:

with McCauley	-4 (78")	3 blade	76.5 dBA
with McCauley	-2 (80")	3 blade	78.1 dBA
with McCauley	-9 (81")	2 blade	77.8 dBA

No determination has been made by the Federal Aviation Administration that the noise level of this airplane is or should be acceptable for operation at, into, or out of any airport.

**3.6 ANTI-COLLISION LIGHT:**

//////////////////// ANTI-COLLISION LIGHT MAY CAUSE ADVERSE EFFECT ON PILOT  
////WARNING//// WHEN FLYING IN VISIBLE MOISTURE, OVERCAST OR HAZE. IT IS  
//////////////////// RECOMMENDED THAT IT BE TURNED OFF UNDER THESE CONDI-  
TIONS.

**SECTION IV - EMERGENCY PROCEDURES**

**4.1 EMERGENCY BASIC RULES:**

To assist the pilot when an emergency occurs, three basic rules are established which apply to most emergencies occurring while airborne. They should be remembered by each crew member.

1. Maintain aircraft control
2. Analyze the situation and take proper action
3. Land as soon as conditions permit

**4.2 ENGINE EMERGENCY SHUT DOWN:**

1. Mixture - Full lean
2. Fuel Selector - OFF
3. Ignition Switch - OFF



**4.3 ENGINE FIRE DURING STARTING:**

1. Mixture - Full lean
2. Throttle - Open
3. Continue cranking for several revolutions. Attempt to draw fire inside engine.
4. Accomplish ENGINE EMERGENCY SHUT DOWN if fire continues.

**4.4 ENGINE FIRE AFTER STARTING:**

1. Accomplish ENGINE EMERGENCY SHUT DOWN
2. Master Switch - OFF

**4.5 EMERGENCY EXIT ON THE GROUND:**

1. Accomplish ENGINE EMERGENCY SHUT DOWN
2. Master Switch - OFF
3. Leave aircraft by either door or kick out side window panels or baggage door.

**4.6 TAKEOFF ABORT: (BEFORE LIFT-OFF)**

1. Throttle - Closed
2. Brakes - As Required

**4.7 ENGINE FAILURE AFTER TAKEOFF OR FORCED LANDING:**

1. Glide - Establish 69K (80 mph) IAS with flaps at 0°
2. Switch Fuel Selector to fullest tank
3. Electric Fuel Pump - ON
4. Mixture Rich, Ignition ON
5. Carburetor Air Control – Pull HOT
6. If engine does not restart, accomplish EMERGENCY SHUT DOWN
7. Wing Flaps - As Required
8. Master Switch - OFF

**4.8 PARTIAL POWER FAILURE DURING FLIGHT OR AFTER TAKEOFF:**

1. Mixture - RICH
2. Carburetor Air Control – Pull HOT
3. Airspeed - Glide at 69K (80 mph) IAS if unable to maintain level flight
4. Fuel Selector - BOTH
5. Electric Fuel Pump - ON
6. Ignition Switch - BOTH
7. Master Switch - ON

**4.9 COMPLETE POWER FAILURE DURING FLIGHT:**

1. Glide - Establish 69K (80 mph) (IAS)
2. Attempt engine airstart if warranted

#### **4.10 ENGINE AIRSTART:**

1. Fuel Selector – BOTH
2. Electric Fuel Pump - ON
3. Mixture – RICH
4. Ignition Switch - BOTH (start if propeller is not turning)
  
5. Auxiliary fuel tank pump switch – ON for tank feeding engine if auxiliary tank has fuel.
6. If engine does not start, try flooded engine clearing procedure with throttle wide open and mixture FULL LEAN.
7. If no start, make forced landing

NOTE: PROPELLER WILL NOT WINDMILL BELOW 61K (70 MPH).

NOTE: AT ALTITUDES OVER 8000 FEET, A LEANER MIXTURE MAY BE REQUIRED.

#### **4.11 ELECTRICAL FIRE:**

1. Master Switch - OFF

#### **4.12 ENGINE FIRE DURING FLIGHT:**

1. Accomplish ENGINE EMERGENCY SHUT DOWN
2. Make forced landing

#### **4.13 SMOKE AND FUME ELIMINATION:**

1. Cabin Heat Knob - IN
2. Cabin Air Knob - IN
3. Upper Air Vents - OPEN
4. Pilot's Window - OPEN (below 104K (120 mph)

#### **4.14 STRUCTURAL DAMAGE:**

1. On Takeoff - Abort
2. In flight, maintain controllable airspeed
3. Climb to safe stall recovery altitude
4. Notify appropriate controlling agency, if appropriate.
5. Determine control difficulty airspeed by slowing down while flying straight ahead. Do not allow the aircraft to stall.
6. Make full stop landing using 4 to 9K (5-10 mph) above difficulty airspeed or above normal approach speed, whichever is higher.

#### **4.15 RECOVERY FROM INADVERTENT SPINS:**

Intentional spins are prohibited. If the aircraft inadvertently enters a spin, simultaneously apply full rudder opposite to the direction of rotation and full nose down elevator with ailerons neutral and reduce power to idle. When the rotation stops, neutralize the rudder and eleva-

MAULE AEROSPACE TECHNOLOGY, INC.  
 AIRPLANE FLIGHT MANUAL  
**MAULE M-7-235C**  
 2800# Uppgross Per STC SA04077CH

tor, and ease back on the control wheel as required to smoothly regain level flight. Wing flaps should be retracted to avoid exceeding the maximum flap speeds during recovery.

**4.16 ALTERNATOR FAILURE:**

Alternator output should be monitored by reference to the ammeter located on the right side of the engine instrument cluster. Should the ammeter indicate a minus deflection when engine RPM is above 900 and/or red "ALTERNATOR OFF WARNING" light is illuminated, push ALT switch OFF then ON. Repeat two times as necessary to reset. If system will not reset, reduce the electrical load as much as possible, land as soon as practical and investigate the electrical system malfunction before further flight.

**SECTION V**

**5.1 WEIGHT AND BALANCE**

Serial Number \_\_\_\_\_ Registration Number \_\_\_\_\_

It is the responsibility of the airplane owner and the pilot to insure that the airplane is loaded properly. The empty weight, empty weight center of gravity and useful load are listed below for this airplane as delivered from the factory. If the airplane has been altered, refer to the aircraft log and/or aircraft records for this information.

**WEIGHT AND BALANCE DATA SUMMARY AS DELIVERED FROM THE FACTORY:**

Basic Empty Weight (including engine oil)..... \_\_\_\_\_ Lbs.  
 Gross Weight..... 2800 Lbs.  
 Useful Load..... \_\_\_\_\_ Lbs.  
 Empty Center of Gravity..... \_\_\_\_\_ Inches  
 Empty Weight Moment..... \_\_\_\_\_ Inch Lbs.

**CENTER OF GRAVITY RANGE:**

<u>Center of Gravity Range</u>	<u>At Weight of</u>
+16.2 to +20.5 inches	2800 lbs.
+12.5 to +20.5 inches	1700 lbs. or less

NOTE: Straight line variation between given points  
 DATUM: Wing leading edge

CERTIFIED BY \_\_\_\_\_ DATE \_\_\_\_\_

MAULE AEROSPACE TECHNOLOGY, INC.  
 AIRPLANE FLIGHT MANUAL  
**MAULE M-7-235C**  
 2800# Uppgross Per STC SA04077CH

DETAILED CALCULATIONS OF EMPTY WEIGHT AND EMPTY WEIGHT CENTER OF GRAVITY AS DELIVERED FROM FACTORY:

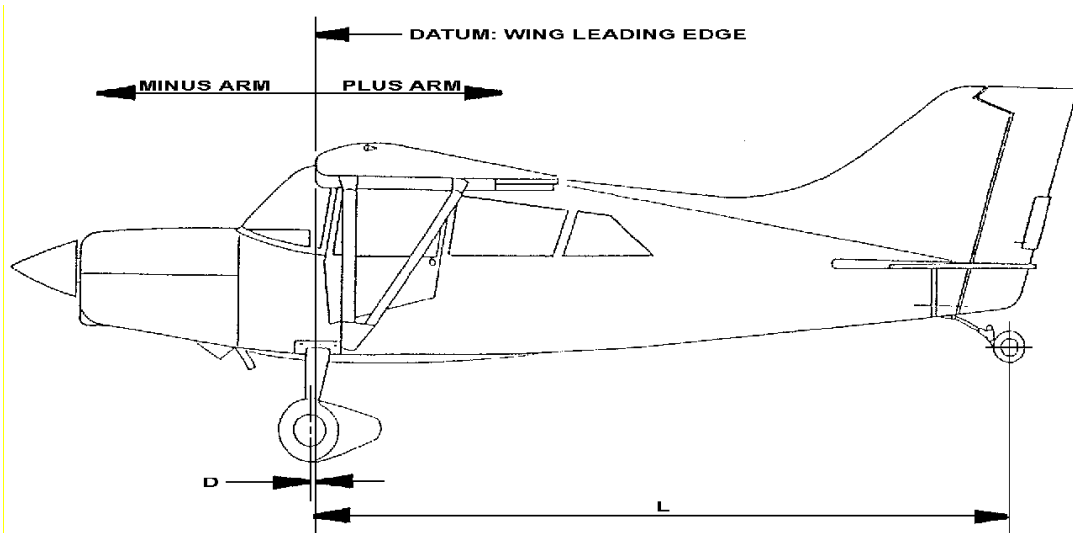

PROCEDURE:

1. Place each of the wheels on a scale with the tailwheel elevated to place the airplane in approximately the flight attitude.
2. Place a level on the leveling mark and leveling lug on the bottom of the right wing near the root. Adjust the height of the tailwheel until the aircraft is level.
3. Measure the following distances:
  - a. Wheel base (**L**) - the horizontal distance from the tailwheel weight point (center of axle) to the main wheel weight point (center of axle).  
 $L = \underline{\hspace{2cm}}$  Inches
  - b. Main Wheel Station (**D**) - the horizontal distance from the main wheel weight point (center of axle) to the datum line.  
 $D = \underline{\hspace{2cm}}$  Inches
4. Measure the weights at the following points:
  - a. **Right** Main Wheel.....=                      Lbs.
  - b. **Left** Main Wheel.....=                      Lbs.
  - c. **Tailwheel**, with tare =                      Lbs., minus tare of                      Lbs.  
 = net Tailwheel wt. (**T**) of                      Lbs.

Total Weight as Weighted (**W**) =                                      Lbs.

MAULE AEROSPACE TECHNOLOGY, INC.  
 AIRPLANE FLIGHT MANUAL  
**MAULE M-7-235C**  
 2800# Uppgross Per STC SA04077CH

The above empty weight includes unusable fuel of 27.6 lbs. at 24 inches and 12 quarts of oil at minus 34 inches, plus all items of equipment as marked on the aircraft Equipment Lists. The certificated empty weight is the above weight less 24 lbs. drainable oil at a minus arm of 34 inches and for this airplane is \_\_\_\_\_lbs. The

corresponding empty weight center of gravity is \_\_\_\_\_inches.

5. Calculations for determining weight, C.G. and moment:

a. Center of Gravity (inches) =  $\frac{L \times T}{W} - D$

i.e., C.G. = \_\_\_\_\_ - \_\_\_\_\_ = \_\_\_\_\_inches.

b. Moment (inch pounds) =  $W \times C.G.$

i.e., Moment = \_\_\_\_\_ x \_\_\_\_\_ = \_\_\_\_\_inch lbs.

EXAMPLE OF WEIGHT AND BALANCE CALCULATION FOR LOADED AIRCRAFT:

An airplane with an empty weight of 1549 lbs. and empty weight moment of 17,349 inch lbs. is loaded with a pilot and front seat passenger, fuel and 125 lbs. for baggage.

Item	Weight, lbs.	C.G. Location	Moment, In. lbs.
Empty Weight (including engine oil)	1549	11.2	17,349
Pilot and Front Passenger	340	*	6,800
Fuel - 43 gal. in Mains plus 30 gal. In Auxiliary Tanks	438	*	10,512
Baggage (Area "C")	<u>125</u>	*	<u>9,000</u>
	2452	17.8	43,661

By locating the point corresponding to 2452 lb. aircraft weight and a C.G. location of 17.8 inches on the Center of Gravity envelope graph, you can see that this point falls within the envelope, signifying the loading is acceptable.

\*Moments can be read directly from the loading graph.

**MAULE M-7-235C**

2800# Uppross Per STC SA04077CH

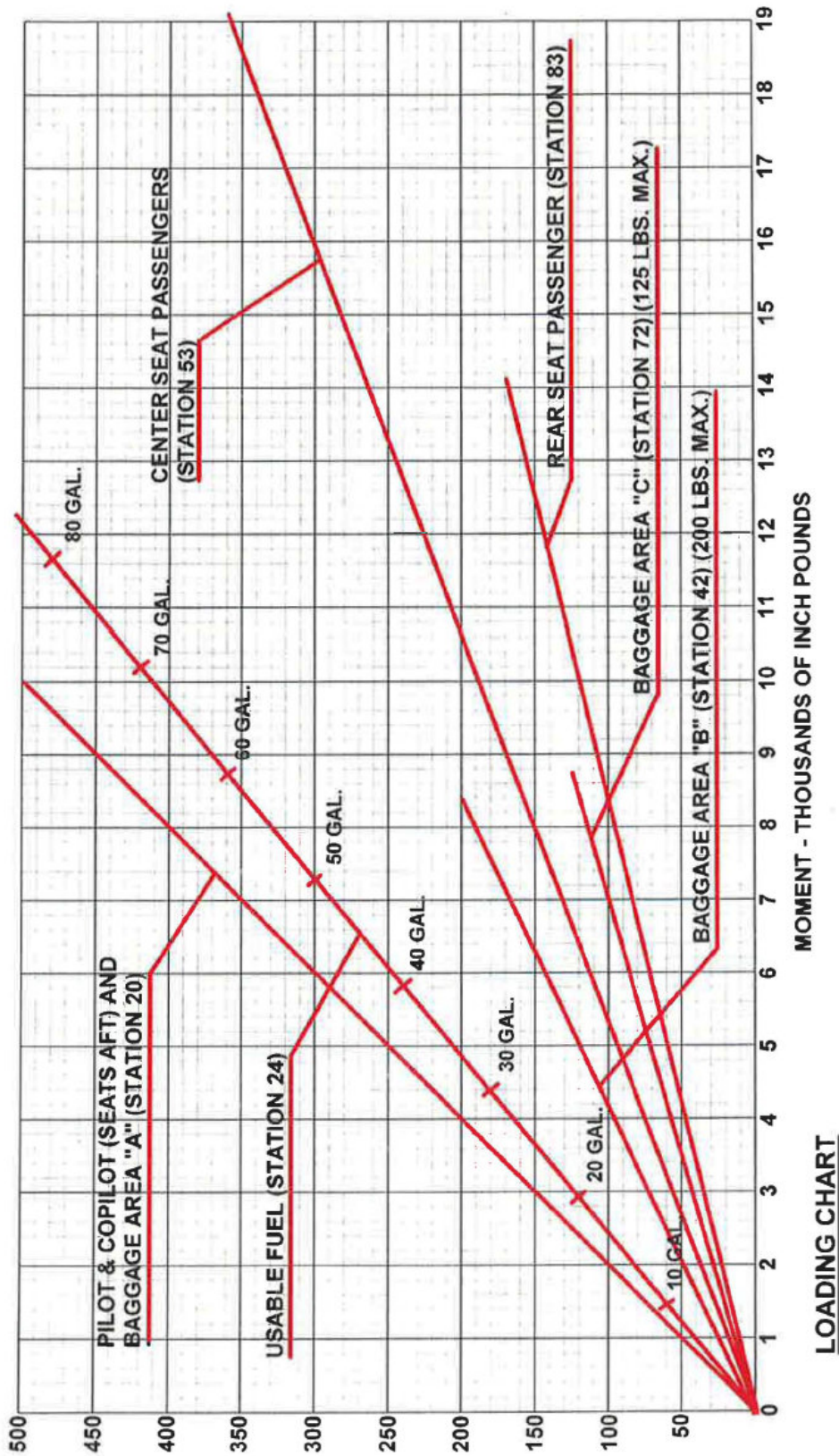

**PROCEDURE FOR DETERMINING WEIGHT & CENTER OF GRAVITY:**

1. Add weight to be carried to the basic empty weight of the aircraft.
2. Find moments of item to be carried by using the above loading graph and add these moments to the empty moment of the aircraft. Divide total moment by total weight for aircraft C.G. location.
3. Using the C.G. location for Step 2, find the point on the Weight and Balance Envelope.

**WEIGHT AND BALANCE ENVELOPE**

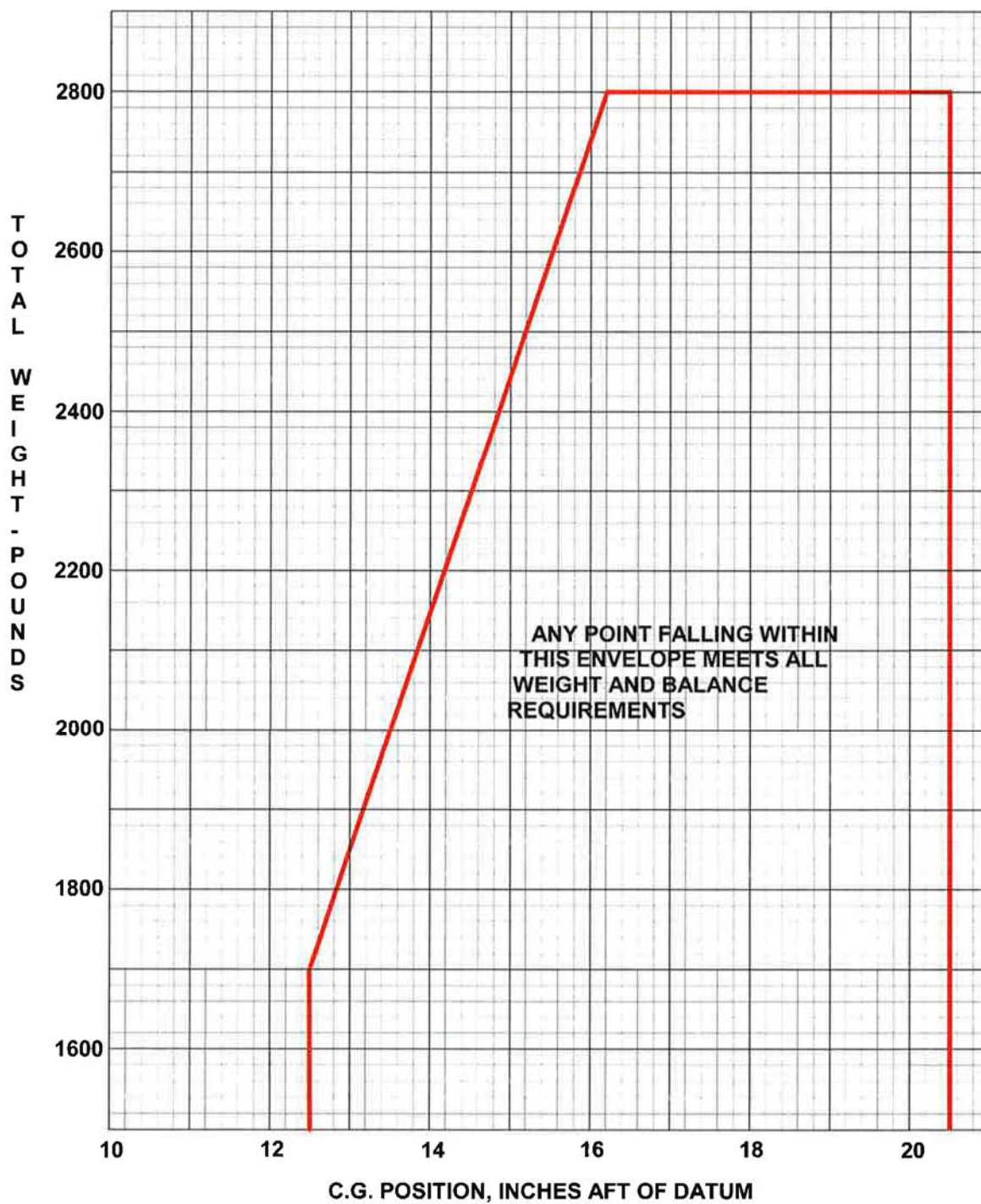

FORM 123

(DATUM: WING LEADING EDGE)

FAA APPROVED  
DATE: 11-16-16

STRUCTURAL CAPACITY CHART

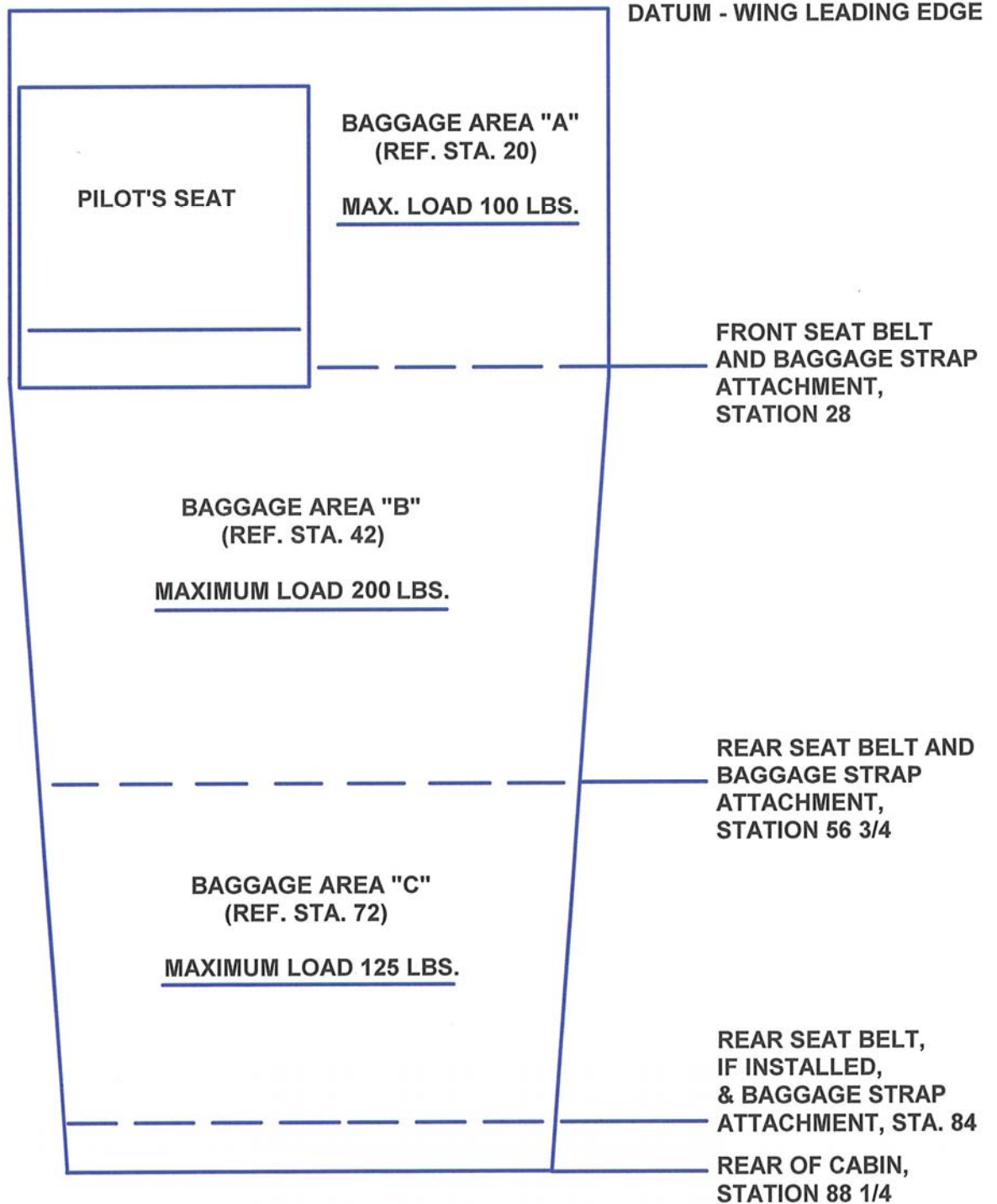



MAULE AEROSPACE TECHNOLOGY, INC.  
AIRPLANE FLIGHT MANUAL  
**MAULE M-7-235C**  
2800# Upgross Per STC SA04077CH

5.2 EQUIPMENT CHANGE - WEIGHT AND BALANCE

SERIAL NO. \_\_\_\_\_ REG. NO. \_\_\_\_\_ MODEL \_\_\_\_\_

ITEM'S (MAKE & MODEL)                      WEIGHT                      ARM                      MOMENTS

Previous Aircraft Empty			

- A. New Empty Weight \_\_\_\_\_ lbs.
- B. New Empty Center of Gravity \_\_\_\_\_ ins.
- C. New Empty Weight C.G. Moment \_\_\_\_\_ in. lbs.
- D. New Useful Load \_\_\_\_\_ lbs.

Supersedes all previous weight and balance data. For aircraft loading see instructions in original weight and balance forms.

BY \_\_\_\_\_ DATE \_\_\_\_\_

FAA APPROVED  
DATE: 11-16-16

## **SECTION VI - AIRCRAFT SERVICING, HANDLING AND MAINTENANCE**

### **6.1 INTRODUCTION:**

Our dealers and distributors are anxious to serve you and will gladly furnish advice as to proper servicing methods. You may also address request for information on any items not covered in the manual to our Service Department (ext. 239 or 227). In correspondence, please be certain to give complete information on serial number, engine make and model.

The aircraft Type Data Plate can be found on the left side of the vertical fin just above the horizontal stabilizer. Also, pertinent engine and propeller data is in the aircraft logbook.

A Service Manual is furnished with each aircraft. Extra copies and a Parts Manual can be obtained by contacting our Service Department.

### **6.2 AIRPLANE INSPECTION PERIOD:**

The airplane must be maintained as outlined in FAR 43. Recommended inspections are outlined in the airplane Maintenance Manual. The owner/operator is responsible for Airworthiness Directives (AD's) that may be issued from time to time. Reference should be made to FAR 91 and FAR 43 requirements for properly certified agency or personnel to accomplish the required FAA inspection and most of the manufacturer's recommended inspections.

It is required that owner's email address, (name and address - optional) and aircraft serial number be sent to [OwnerAlert@mauleairinc.com](mailto:OwnerAlert@mauleairinc.com) for notification of any Maule Service Letters, Service Bulletins and/or Manual updates released for downloading from our website at [mauleairinc.com](http://mauleairinc.com).

### **6.3 PREVENTIVE MAINTENANCE THAT MAY BE ACCOMPLISHED BY A CERTIFIED PILOT:**

- A. A certified pilot who owns or operates an airplane not used as an air carrier is authorized by FAR Part 43 to perform limited preventive maintenance on his airplane. Refer to FAR Part 43 for list of things the pilot may do. Pilots operating aircraft of other than U.S. registry should refer to the regulations of the country of certification for information on preventive maintenance that may be performed by pilots. All other maintenance required on airplane is to be accomplished by appropriately licensed personnel and that airplane dealer or service station should be contacted for further information.
- B. Preventive maintenance should be accomplished in accordance with the appropriate airplane Maintenance Manual. Manual should be obtained prior to performing preventive maintenance to be sure that proper procedures are followed.

### **6.4 ALTERATIONS OR REPAIRS TO AIRPLANE:**

Alterations or repairs to airplane must be accomplished by licensed personnel. The FAA should be contacted prior to any alterations on airplane to insure that Airworthiness of the airplane is not violated.

MAULE AEROSPACE TECHNOLOGY, INC.  
AIRPLANE FLIGHT MANUAL

***MAULE M-7-235C***

2800# Upgross Per STC SA04077CH

**SECTION VII - MANUFACTURER'S DATA**

*7.1 OPTIONAL AND REQUIRED EQUIPMENT LIST - PROVIDED FOR EACH AIRPLANE*